

AUTODIDAKTIKA

freie, selbstorganisierte Bildungsbörse

[▶ Diashow vorführen](#)

[📡 Abonnieren](#)

***Wollen wir all das
nicht lieber selber
in die Hand
nehmen, als es nur
den Institutionen
zu überlassen?***



**Lesen lernen,
Neues erfahren,
über Gelesenes austauschen**

**Lernpartner
suchen und finden**



**mit Leuten treffen,
diskutieren, lesen,
etwas erarbeiten**



**experimentieren,
erfinden**

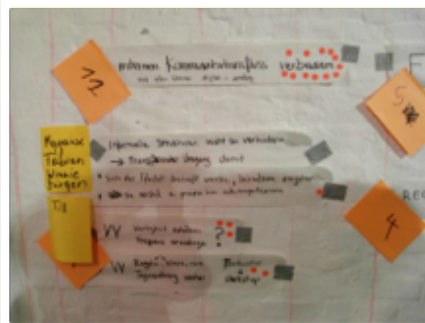

**gemeinsam denken
und etwas
Neues entwickeln**



**anschaulich lernen,
gemeinsam in Museen gehen**



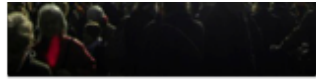

sich selber organisieren



spielerisch forschen



**Maschinen kennenlernen,
vom Wissen erfahrener Menschen
profitieren**



mit Werkzeug hantieren



sich an etwas heranwagen

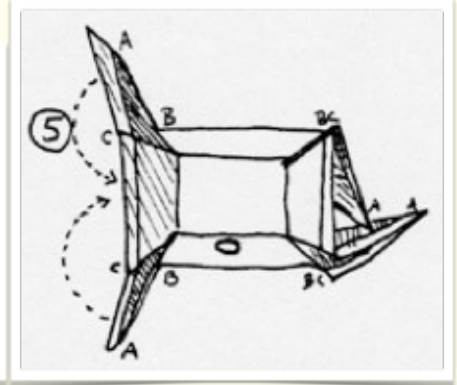

Wissen weitergeben



**beobachten,
anfassen**

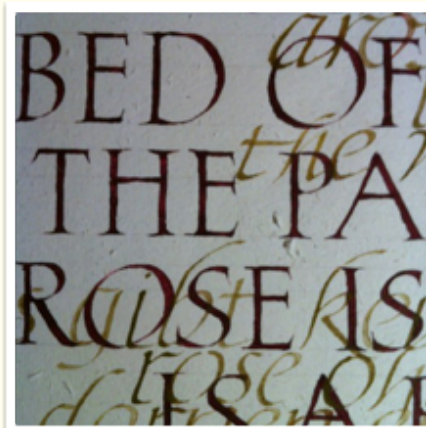

Texte schreiben



**formen, gestalten,
betrachten, besprechen**